

Surfside Beach City Council Meeting

Tuesday March 12, 2024

Village of Surfside Beach

1304 Monument Drive

Surfside Beach, TX 77541

An agenda information packet is available for public inspection on the website at
www.surfsidetx.org

NOTICE IS HEREBY GIVEN that the City Council of the Village of Surfside Beach will conduct a budget workshop scheduled for **7:00 p.m. on Tuesday March 12, 2024**. To view the meeting electronically please use the following website:

<https://us02web.zoom.us/j/84253545017?pwd=VHFGMXRoZmJHNG5lcDBISlJ3MldjUT09>

Meeting ID 842 5354 5017 Password 1304

The City Council reserves the right to meet in closed session on any agenda item, should the need arise and if applicable, pursuant to authorization by Title 5, Chapter 551, of the Texas Government Code.

COUNCIL MEETING:

- 1) CALL TO ORDER, QUORUM IN ATTENDANCE
- 2) INVOCATION, PLEDGE OF ALLEGIANCE
- 3) Mayor/council/department head reports
- 4) Business of visitors not on the agenda.
- 5) ALL ITEMS UNDER THE CONSENT AGENDA ARE CONSIDERED TO BE SELF-EXPLANATORY, AND THE COUNCIL WILL ENACT THEM WITH ONE MOTION. UNLESS A COUNCIL MEMBER SO REQUESTS, NO SEPARATE DISCUSSION OF THESE ITEMS WILL OCCUR.

CONSENT AGENDA:

- A. Consider approval of minutes from the Council meeting on January 9, 2024.
 - B. Consider approval of accounts payable from January, 2024.
 - C. Consider approval of the Historical reenactment, cannon fire, and use of Council chambers for the 18th of May 2024. *Gerber*
 - D. Approve estimate from Green's Services for road stripping. *Bisso*
 - E. Approve extending the Interlocal Cooperation Contract for the Failure to Appear Program between the Village and the Department of Public Safety of the State of Texas
-
- 6) Discuss and take possible action to adopt Ordinance No. 2023.11.14 regarding lighting as submitted by the Planning Commission. *Bisso*

- 7) Discuss and take possible action to use funds from the Municipal Court Security Fund for the purchase of a lidar gun and a 16 TB external hard drive for the Surfside Beach police department. *Bisso*
- 8) Discuss and take possible action on Ordinance 2024.02.13 regarding NO Parking along Bluewater Highway. *Bisso*
- 9) Discuss and take possible action regarding a Notice of CenterPoint Energy Houston Electric, LLC Filing to Change Rates. *Bisso*
- 10) Discuss and take possible action regarding Ordinance 2024.03.12 amending the Surfside Beach Water Conservation plan by updating the five year and ten year goals. *Ingram*
- 11) Discuss and take possible action to purchase excavator from Alpha & Omega Construction Equipment for no more than \$29,500.00 through the Government Capital Corporation financing. *Bisso*
- 12) Discuss and take possible action to establish the Chief's Advisory Panel for the Surfside Beach Texas Police Department. *Gerber*
- 13) Discuss and take possible action regarding: Approval of location near the Timeline Fence for Daughters of the Republic of Texas and future insignia medallions from other historically related groups, and proposed landscaping around monument. *Gerber*
- 14) Discuss and take possible action to move city hall to Stahlman Park. *Jalifi*
- 15) **Executive Session:**
Surfside City Council will adjourn into an EXECUTIVE SESSION (closed executive session pursuant to section 551.074 of the Texas Government Code) to discuss personnel matters - specifically, matters involving the appointment/re-appointment, employment, evaluation reassignment, resignation and duties of the Judges serving the Surfside Municipal Court.
- 16) Action, if any out of executive session, and adjourn.

CERTIFICATION

I hereby certify that a true and correct copy of the above and foregoing "Notice of Meeting" by the City Council was posted on the front bulletin board of the City Hall of the Village of Surfside Beach, Texas. Said notice was posted Thursday, March 7, 2024 at or before 6:00 PM and remained so posted continuously for at least 72 hours before the scheduled time and date of the aforementioned meeting.

City Secretary

Minutes of Meeting of the City Council

Tuesday, January 9, 2024 – 7:00 PM

Village of Surfside Beach

1304 Monument Drive

Surfside Beach, TX 77541

1) CALL TO ORDER, QUORUM IN ATTENDANCE

Mayor Bisso called the meeting to order at 7:00 p.m. and noted that a quorum of City Council was in attendance with Robertson attending via zoom.

2) INVOCATION, PLEDGE OF ALLEGIANCE

Jalifi gave the invocation and Mayor Bisso led the Pledge of Allegiance.

3) Mayor/council/department head reports

Parsch – the GLO has published the amendment to the Beach Access and Dune Plan and should be approved by February 12, 2024;

Mayor Bisso – gave an update regarding the groin project, the Stahlman Park repair bids, on the HGAC sewer grant the GLO is asking for more information again; Beach Drive walkovers; maintenance of Village owned buildings and inspections.

Chief – gave monthly PD report;

Hinton – gave the monthly EMS report;

4) Business of visitors not on the agenda. None.

5) ALL ITEMS UNDER THE CONSENT AGENDA ARE CONSIDERED TO BE SELF-EXPLANATORY, AND THE COUNCIL WILL ENACT THEM WITH ONE MOTION. UNLESS A COUNCIL MEMBER SO REQUESTS, NO SEPARATE DISCUSSION OF THESE ITEMS WILL OCCUR.

CONSENT AGENDA:

A. Consider approval of minutes from the Council meeting on December 12, 2023.

B. Consider approval of accounts payable from December 2023.

C. Consider approval of St. Patrick's Day parade and all activities pertaining to St. Patrick's Day on March 16.

Motion was made by Prats to approve items A & B and remove item c to be discussed. Motion was seconded by Jalifi and approved unanimously.

Motion was made by Prats to approve item C as amended to state "St. Patrick's Day Committee's events". Motion was seconded by Jalifi and approved unanimously.

6) Discuss and take possible action on amending Sec 2 of the Surfside Beach Code of Ordinances to require appointed commission, committee and board chairs to be full time residents residing within the Village of Surfside Beach for at least 11 months out of the year during their term.

This item was removed from the agenda on the advice of Counsel.

- 7) Discuss and take possible action to adopt Ordinance No. 2023.11.14 regarding lighting as submitted by the Planning Commission.

Motion was made by Gerber to table and send back to Planning Commission in January. Motion was seconded by Jalifi and approved unanimously.

- 8) Discuss purchasing heavy equipment and other rentals.

Discussion only.

- 9) Discuss and take action to approve Ordinance 2024.01.09 calling the 2024 Municipal Election and authorizing Mayor Bisso to enter into a contract with Brazoria County for election administration.

Motion was made by Prats to approve Ordinance 2024.01.09 calling the 2024 Municipal Election and authorizing Mayor Bisso to enter into a contract with Brazoria County for election administration. Motion was seconded by Jalifi and passed unanimously.

- 10) Added item: A town hall meeting to discuss the Hotel/Motel rates and usage of funds was scheduled for Feb. 6 at 6:00 p.m.

Motion was made by Parsch to plan a town hall meeting. Motion was seconded by Jalifi and passed unanimously.

Adjourn.

Gregg Bisso, Mayor

Attest:

Amanda Davenport, City Secretary

VILLAGE OF SURFSIDE BEACH BF
Transaction List by Vendor

| Type | Date | Num | January 2024 | Memo | Amount |
|-----------------|------------|--------------|------------------------------------|------|-----------|
| Bill | 01/05/2024 | 33753773-008 | | | -1,912.80 |
| Liability Check | 01/04/2024 | 104202490 | 74-2053043 | | -1,255.42 |
| Liability Check | 01/18/2024 | 118202490 | 74-2053043 | | -1,217.24 |
| Bill | 01/22/2024 | | REMOVE AND BUILD NEW RAMP AT WHELK | | -6,000.00 |
| Bill | 01/03/2024 | 64547 | unit 709 | | -391.73 |
| Liability Check | 01/18/2024 | 118202491 | 0010073128/53144 | | -486.55 |

HERC RENTALS

IRS

Jesus Cisneros

Performance Trans & Auto Repair, Inc

TEXAS CHILD SUPPORT SDU

**Village of Surfside Beach GF
Transaction List by Vendor
January 2024**

| | Type | Date | Num | Memo | Amount |
|--|-----------------|------------|-----------|------------|------------|
| A/C SERVICES LLC | Bill Pmt -Check | 01/02/2024 | 5718 | | -139.00 |
| AXON ENTERPRISE INC | Bill Pmt -Check | 01/15/2024 | 5705 | INUS207709 | -2,335.50 |
| Baker Donelson | Bill Pmt -Check | 01/02/2024 | 5719 | | -616.50 |
| BLUE RIBBON TACTICAL | Bill | 01/02/2024 | | | -2,085.00 |
| | Bill | 01/11/2024 | | | -2,322.21 |
| | Bill | 01/11/2024 | | | -1,070.00 |
| BOUNDTREE MEDICAL, LLC | Bill Pmt -Check | 01/02/2024 | 5720 | | -137.97 |
| | Bill Pmt -Check | 01/15/2024 | 5707 | | -149.76 |
| BRINKS | Bill Pmt -Check | 01/02/2024 | 5721 | | -250.66 |
| C & M CUSTOM SIGNS & GRAPHICS | Bill Pmt -Check | 01/02/2024 | 5722 | | -300.00 |
| Cintas | Bill Pmt -Check | 01/02/2024 | 5723 | | -225.37 |
| | Bill Pmt -Check | 01/15/2024 | 5708 | | -676.11 |
| ENGIE ENERGY | Bill Pmt -Check | 01/18/2024 | 20240118 | | -2,141.24 |
| Function 4, LLC | Bill Pmt -Check | 01/02/2024 | 5724 | | -50.75 |
| Henry Schein, Inc | Bill Pmt -Check | 01/02/2024 | 5725 | | -175.82 |
| | Bill Pmt -Check | 01/15/2024 | 5709 | | -292.24 |
| IRS | Liability Check | 01/04/2024 | 104202490 | 74-2053043 | -13,195.08 |
| | Liability Check | 01/18/2024 | 118202490 | 74-2053043 | -11,399.94 |
| | Liability Check | 01/18/2024 | 118202492 | 74-2053043 | -199.24 |
| | Liability Check | 01/25/2024 | 1252024 | 74-2053043 | -929.12 |
| JANET SOLIS. | | | | | |

Village of Surfside Beach GF
Transaction List by Vendor

January 2024

| Type | Date | Num | Memo | Amount |
|---|------------|-----------|---|------------|
| Bill Pmt -Check | 01/02/2024 | 5726 | REIMBURSAMENT FOR EMPLOYEE CHRISTI | -116.46 |
| Bill Pmt -Check | 01/15/2024 | 5710 | | -126.14 |
| KBCBA. | | | | |
| Bill Pmt -Check | 01/15/2024 | 5711 | | -230.00 |
| Kristin R Bulanek | | | | |
| Bill Pmt -Check | 01/15/2024 | 5712 | | -642.88 |
| Lexis Nexis | | | | |
| Bill Pmt -Check | 01/02/2024 | 5727 | 1359205 | -90.00 |
| LOWES | | | | |
| Bill Pmt -Check | 01/15/2024 | 5713 | Statement Date 12/25/2023 | -1,202.19 |
| O'REILLY AUTO PARTS | | | | |
| Bill Pmt -Check | 01/15/2024 | 5714 | | -995.62 |
| PATTON RITTER | | | | |
| Check | 01/04/2024 | 104202494 | | -2,000.00 |
| PERFORMANCE TRANS & AUTO REPAIR IN | | | | |
| Bill Pmt -Check | 01/02/2024 | 5728 | | -1,641.18 |
| Bill Pmt -Check | 01/15/2024 | 5715 | | -258.10 |
| R & M TELEPHONE SERVICE, INC. | | | | |
| Bill Pmt -Check | 01/02/2024 | 5729 | | -30.60 |
| SMITH MUNICIPAL SUPPLIES | | | | |
| Bill Pmt -Check | 01/02/2024 | 5730 | | -599.26 |
| STATE COMPTROLLER | | | | |
| Liability Check | 01/25/2024 | 125202401 | 74-205304-3 | -87.54 |
| SUBURBAN PROPANE | | | | |
| Bill Pmt -Check | 01/11/2024 | 1112024 | 7905-518193 | -532.61 |
| Teresa Timms. | | | | |
| Bill Pmt -Check | 01/02/2024 | 5731 | 01/12/24 & 01/19/24 CLEANINGS | -300.00 |
| Bill Pmt -Check | 01/15/2024 | 5716 | 12/28/23 & 01/05/2024 | -300.00 |
| TEXAS COMPTROLLER OF PUBLIC ACCOUNTS | | | | |
| Bill Pmt -Check | 01/02/2024 | 5732 | PERIOD OF LIABILITY 04/01/2023 - 06/30/2023 | -3,699.87 |
| TML GROUP INSURANCE | | | | |
| Check | 01/31/2024 | 130202401 | | -21,582.44 |
| TMRS | | | | |

Village of Surfside Beach GF
Transaction List by Vendor

January 2024

| Type | Date | Num | Memo | Amount |
|-----------------|------------|------------|------------------|------------|
| Liability Check | 01/10/2024 | 1102024 | 01233 | -20,310.49 |
| Liability Check | 01/04/2024 | 104202491 | | -650.31 |
| Liability Check | 01/18/2024 | 118202491 | | -650.31 |
| Liability Check | 01/18/2024 | 118202493 | | -286.62 |
| Bill Pmt -Check | 01/15/2024 | 5717 | | -9,070.00 |
| Bill Pmt -Check | 01/15/2024 | 5733 | 5131-7704436-001 | -27,265.64 |
| Check | 01/31/2024 | 5734 | VOID: | 0.00 |
| Bill | 01/01/2024 | MXv-006497 | | -411.83 |

TX CHILD SPT SDU

VOSB VFD

WASTE CONNECTIONS

YAKLIN FORD

Zultys

**VILLAGE OF SURFSIDE BEACH HF
Transaction List by Vendor**

January 2024

| Type | Date | Num | Memo | Amount |
|-----------------|------------|-------------|-------------------------------|-----------|
| Bill Pmt -Check | 01/22/2024 | 2458 | Stahlman Cancellation Refund | -1,450.00 |
| Bill Pmt -Check | 01/22/2024 | 2459 | | -750.00 |
| Bill Pmt -Check | 01/18/2024 | 20240118 | | -320.46 |
| Liability Check | 01/04/2024 | 104202490 | 74-2053043 | -337.82 |
| Liability Check | 01/18/2024 | 118202490 | 74-2053043 | -338.20 |
| Bill Pmt -Check | 01/11/2024 | 2457 | | -2,500.00 |
| Bill Pmt -Check | 01/22/2024 | 2460 | | -200.00 |
| Bill Pmt -Check | 01/22/2024 | 2461 | Refund for chili cook off fee | -25.00 |
| Bill | 01/04/2024 | A2024-712 | | -240.00 |
| Check | 01/04/2024 | 104202402 | | -1,549.23 |
| Check | 01/18/2024 | 115202402 | | -1,549.23 |
| Bill | 01/04/2024 | 3567456V131 | | -248.78 |

Daniela Andreoni

Dennis Davis

ENGIE RESOURCES

INTERNAL REVENUE SERVICE

James Burriss

KEEP TEXAS BEAUTIFUL

Oyster Creek Community VFD

PATRICK'S ENTERPRISES INC

THE ART OF PROFIT

Waste Connections

VILLAGE OF SURFSIDE BEACH SF
Transaction List by Vendor

January 2024

| | Type | Date | Num | Memo | Amount |
|---|-----------------|------------|-----------|---------------------------------|------------|
| AT&T | Bill Pmt -Check | 01/04/2024 | 3421 | Monthly service Nov 27 - Dec 26 | -182.89 |
| Braz Cty Groundwater Conservation Distrct | Bill Pmt -Check | 01/04/2024 | 3433 | Renewal fee | -600.00 |
| Brazoria County Health Water Lab | Bill | 01/11/2024 | | Account #125 | -75.00 |
| CHLORINATOR MAINT. CO. INC. | Bill Pmt -Check | 01/04/2024 | 3422 | | -492.80 |
| CITY OF FREEPORT | Bill Pmt -Check | 01/04/2024 | 3423 | Due 12/21/2023 | -13,117.11 |
| Comcast | Bill Pmt -Check | 01/04/2024 | 3424 | Dec 22 - Jan 21 | -147.30 |
| DXI INDUSTRIES | Bill Pmt -Check | 01/04/2024 | 3425 | | -4,868.64 |
| ENGIE RESOURCES | Bill Pmt -Check | 01/18/2024 | 20240118 | | -5,117.33 |
| Hawkins, Inc. | Bill Pmt -Check | 01/04/2024 | 3426 | | -1,527.75 |
| HERC RENTALS | Bill Pmt -Check | 01/04/2024 | 3427 | | -5,916.13 |
| IRS | Liability Check | 01/04/2024 | 104202490 | 74-2053043 | -2,440.26 |
| | Liability Check | 01/18/2024 | 118202490 | 74-2053043 | -2,356.96 |
| Karyn Conner | Bill | 01/23/2024 | | Deposit Reimbursement | -130.00 |
| PENNEY'S ELECTRIC INC | Bill Pmt -Check | 01/04/2024 | 3428 | | -11,196.75 |
| RVS Software | Bill Pmt -Check | 01/04/2024 | 3429 | 5215 | -191.01 |
| Sun Coast Resources Inc | Bill Pmt -Check | 01/04/2024 | 3430 | 10236754 | -1,353.07 |
| UNITED RENTALS | Bill Pmt -Check | 01/04/2024 | 3431 | | -2,577.49 |
| Water of Texas | Bill Pmt -Check | 01/04/2024 | 3432 | | -526.00 |

Green's Services

P.O. Box 854
Highlands, TX 77562

Estimate

| | |
|-----------|------------|
| Date | Estimate # |
| 2/23/2024 | 2964 |

| |
|---|
| Name / Address |
| City of Surfside 1304 Monument Dr. Surfside, Tx. 77541 |

| | | |
|----------------|------------|----------------|
| Terms | Rep | Project |
| Due on receipt | JG | |

| Item | Description | Qty | Rate | Amount | Disco... | Total |
|--------------|--|-----|----------|----------|----------|----------|
| Striping | (Beach Road)-Painting of lines on Road. | 1 | 1,975.00 | 1,975.00 | | 1,975.00 |
| Pitch & Roll | (Beach Road)-Hot mix asphalt installed in pot holes, tacked and rolled/tamped in. - Misc Other Pot Holes on other roads | 1 | 1,775.00 | 1,775.00 | | 1,775.00 |
| Striping | (Surf Road)-Painting of lines on Bike/walk Path. | 1 | 4,300.00 | 4,300.00 | | 4,300.00 |
| Striping | (Surf Road)-Painting of lines on Road(Center Line and Stop Bars) | 1 | 1,975.00 | 1,975.00 | | 1,975.00 |
| Striping | (Ft Velasco)-Painting of Center Line. | 1 | 1,650.00 | 1,650.00 | | 1,650.00 |
| Striping | (Blue Water Hwy)-Painting of lines on Road | 1 | 7,900.00 | 7,900.00 | | 7,900.00 |
| Striping | (Blue Water Hwy)-Painting of lines, stencils and stop bars on Cart Path! Will need to be scraped with skid steer to paint on some areas! ~~~All Lines Heavy Coated w/Glass Beads~~~ | 1 | 7,500.00 | 7,500.00 | | 7,500.00 |

| | | |
|--|-----------------|-------------|
| Thank you for the opportunity to bid your work. Signature _____ | Subtotal | \$27,075.00 |
|--|-----------------|-------------|

| | | |
|--|-------------------------|--------|
| Thank You for the Oppurtunity to bid your work! We will meet or beat any reasonable bid! | Sales Tax (0.0%) | \$0.00 |
|--|-------------------------|--------|

| |
|----------------|
| Phone # |
| 979-292-5037 |

| |
|-------------------|
| E-mail |
| jimgm68@yahoo.com |

| | |
|--------------|-------------|
| Total | \$27,075.00 |
|--------------|-------------|

**Interlocal Cooperation Contract
Failure to Appear Program**

State of Texas

County of Brazoria

I. PARTIES AND AUTHORITY

This Interlocal Cooperation Contract (Contract) is entered into between the Department of Public Safety of the State of Texas (DPS), an agency of the State of Texas and the Municipal Court of the [City or County] of Village of Surfside Beach (Court), a political subdivision of the State of Texas, referred to collectively in this Contract as the Parties, under the authority granted in Tex. Transp. Code Chapter 706 and Tex. Gov't Code Chapter 791 (the Interlocal Cooperation Act).

II. BACKGROUND

A peace officer authorized to issue citations within the jurisdiction of the Court must issue a written warning to each person to whom the officer issues a citation for a traffic law violation. This warning must be provided in addition to any other warnings required by law. The warning must state in substance that if the person fails to appear in court for the prosecution of the offense or if the person fails to pay or satisfy a judgment ordering the payment of a fine and cost in the manner ordered by the Court, the person may be denied renewal of the person's driver license.

As permitted under Tex. Transp. Code § 706.008, DPS contracts with a private vendor (Vendor) to provide and establish an automated Failure to Appear (FTA) system that accurately stores information regarding violators subject to the provisions of Tex. Transp. Code Chapter 706. DPS uses the FTA system to properly deny renewal of a driver license to a person who is the subject of an FTA system entry generated from an FTA Report.

An FTA Report is a notice sent by Court requesting a person be denied renewal of a driver's license in accordance with this Contract. The Court may submit an FTA Report to DPS's Vendor if a person fails to appear or fails to pay or satisfy a judgment as required by law. There is no requirement that a criminal warrant be issued in response to the person's failure to appear.

III. PURPOSE

This Contract applies to each FTA Report submitted by the Court to DPS or its Vendor and accepted by DPS or its Vendor.

IV. PERIOD OF PERFORMANCE

This Contract will be effective on the date of execution and terminate five years from that execution date unless terminated earlier in accordance with Section VII.C, *General Terms and Conditions, Termination*.

V. COURT RESPONSIBILITIES

A. FTA Report

For a matter involving any offense which a Court has jurisdiction of under Tex. Code Crim. Proc. Chapter 4, where a person fails to appear for a complaint or citation or fails to pay or

satisfy a judgment ordering payment of a fine and cost in the manner ordered by the Court, the Court will supply DPS, through its Vendor, an FTA report including the information that is necessary to deny renewal of the driver license of that person. The Court must make reasonable efforts to ensure that all FTA Reports are accurate, complete, and non-duplicative. The FTA Report must include the following information:

1. the jurisdiction in which the alleged offense occurred;
2. the name of the court submitting the report;
3. the name, date of birth, and Texas driver license number of the person who failed to appear or failed to pay or satisfy a judgment;
4. the date of the alleged violation;
5. a brief description of the alleged violation;
6. a statement that the person failed to appear or failed to pay or satisfy a judgment as required by law;
7. the date that the person failed to appear or failed to pay or satisfy a judgment; and
8. any other information required by DPS.

B. Clearance Reports

The Court that files the FTA Report has a continuing obligation to review the FTA Report and promptly submit appropriate additional information or reports to the Vendor. The clearance report must identify the person, state whether or not a fee was required, and advise DPS to lift the denial of renewal and state the grounds for the action. All clearance reports must be submitted immediately, but no later than two business days from the time and date that the Court receives appropriate payment or other information that satisfies the person's obligation to that Court.

To the extent that a Court uses the FTA system by submitting an FTA Report, the Court must collect the statutorily required \$10.00 reimbursement fee from the person who failed to appear, pay or satisfy a judgment ordering payment of a fine and cost in the manner ordered by the Court. If the person is acquitted of the underlying offense for which the original FTA Report was filed or found indigent by the court, the Court will not require payment of the reimbursement fee.

Court must submit a clearance report for the following circumstances:

1. the perfection of an appeal of the case for which the warrant of arrest was issued or judgment arose;
2. the dismissal of the charge for which the warrant of arrest was issued or judgment arose;
3. the posting of a bond or the giving of other security to reinstate the charge for which the warrant was issued;
4. the payment or discharge of the fine and cost owed on an outstanding judgment of the Court; or
5. other suitable arrangement to satisfy the fine and cost within the Court's discretion.

After termination of the Contract, the Court has a continuing obligation to report dispositions and collect fees for all violators in the FTA system at the time of termination. Failure to comply with the continuing obligation to report will result in the removal of all outstanding entries of the Court in the FTA Report, resulting in the lifting of any denied driver license renewal status from DPS.

C. Quarterly Reports and Audits

Court must submit quarterly reports to DPS in a format established by DPS.

Court is subject to audit and inspection at any time during normal business hours and at a mutually agreed upon location by the state auditor, DPS, and any other department or agency, responsible for determining that the Parties have complied with the applicable laws. Court must provide all reasonable facilities and assistance for the safe and convenient performance of any audit or inspection.

Court must correct any non-conforming transactions performed by the Court, at its own cost, until acceptable to DPS.

Court must keep all records and documents regarding this Contract for the term of this Contract and for seven years after the termination of this Contract, or until DPS or the State Auditor's Office (SAO) is satisfied that all audit and litigation matters are resolved, whichever period is longer.

D. Accounting Procedures

Court must keep separate, accurate, and complete records of the funds collected and disbursed and must deposit the funds in the appropriate municipal or county treasury. Court may deposit such fees in an interest-bearing account and retain the interest earned on such accounts for the Court.

Court will allocate \$6.00 of each \$10.00 reimbursement fee received for payment to the Vendor and \$4.00 for credit to the general fund of the municipal or county treasury.

E. Non-Waiver of Fees

Court will not waive the \$10.00 reimbursement fee for any person that has been submitted on an FTA Report, unless any of the requirements in Tex. Trans. Code § 706.006(a) or §706.006(d) are met.

Failure to comply with this section will result in: (i) termination of this Contract for cause; and (ii) the removal of all outstanding entries of the Court in the FTA Report, resulting in the lifting of any denied driver license renewal status from DPS.

F. Litigation Notice

The Court must make a good-faith attempt to immediately notify DPS in the event that the Court becomes aware of litigation in which this Contract or Tex. Transp. Code Chapter 706 is subject to constitutional, statutory, or common-law challenge, or is struck down by judicial decision.

VI. DPS's RESPONSIBILITIES

DPS will not continue to deny renewal of the person's driver license after receiving notice from the Court that the FTA Report was submitted in error or has been destroyed in accordance with the Court's record retention policy.

VII. PAYMENTS TO VENDOR

Court must pay the Vendor a fee of \$6.00 per person for each violation that has been reported to the Vendor and for which the Court has subsequently collected the statutorily required \$10.00 reimbursement fee. In the event that the fee has been waived by Tex. Trans. Code § 706.006(a) or §706.006(d), no payment will be made to the Vendor.

Court agrees that payment will be made to the Vendor no later than the last day of the month following the close of the calendar quarter in which the payment was received by the Court.

DPS will not pay Vendor for any fees that should have been submitted by a Court.

VIII. GENERAL TERMS AND CONDITIONS

- A. Compliance with Law.** This Contract is governed by and construed under and in accordance with the laws of the State of Texas. The Court understands and agrees that it will comply with all local, state, and federal laws in the performance of this Contract, including administrative rules adopted by DPS.
- B. Notice.** The respective party will send the other party notice as noted in this section. Either party may change its information by giving the other party written notice and the effective date of the change.

| Court | Department of Public Safety |
|---|--|
| Attn.: Village of Surfside Beach Municipal Court | Enforcement & Compliance Service 5805 North Lamar Blvd., Bldg A Austin, Texas 78752-0001 (512) 424-5311 [fax] Driver.Improvement@dps.texas.gov (512) 424-7172 |
| Address: 1304 Monument Dr | |
| Address: Surfside Beach Texas 7541 | |
| Fax: 979.373.0699 | |
| Email: cc@Surfsidetx.org | |
| Phone: 979.283.1531 Ext 105 | |

C. Termination.

Either party may terminate this Contract with 30 days' written notice.

DPS may also terminate this Contract for cause if Court doesn't comply with Section V.C., *Quarterly Reports and Audits* and V.E., *Non- Waiver of Fees*.

If either Party is subject to a lack of appropriations that are necessary for that Party's performance of its obligations under this Contract, the Contract is subject to immediate cancellation or termination, without penalty to either Party.

D. Amendments.

This contract may only be amended by mutual written agreement of the Parties.

E. Miscellaneous.

1. The parties shall use the dispute resolution process provided for in Chapter 2260 of the Texas Government Code to resolve any disputes under this Contract; provided

however nothing in this paragraph shall preclude either Party from pursuing any remedies available under Texas law.

- 2. This Contract shall not constitute or be construed as a waiver of any of the privileges, rights, defenses, remedies, or immunities available to either Party or the State of Texas.
- 3. Any alterations, additions, or deletions to the terms of the contract that are required by changes in federal or state law or regulations are automatically incorporated into the contract without written amendment hereto, and shall become effective on the date designated by such law or by regulation.

CERTIFICATIONS

The Parties certify that (1) the Contract is authorized by the governing body of each party; (2) the purpose, terms, rights, and duties of the Parties are stated within the Contract; and (3) each party will make payments for the performance of governmental functions or services from current revenues available to the paying party.

The undersigned signatories have full authority to enter into this Contract on behalf of the respective Parties.

Court*

Department of Public Safety

Authorized Signatory

Driver License Division Chief or Designee

Title

Date

Date

*An additional page may be attached if more than one signature is required to execute this Contract on behalf of the Court. Each signature block must contain the person’s title and date.



LiuGong Order Confirmation



Bill To: PUBLIC WORKS VILLAGE OF SURFSIDE BEACH
Address: 1304 MONUMENT BLVD
 SURFSIDE BEACH, TX 77541
Contact: ERICK INGRAM
Phone:
Email:

Ship To: TBD
Address:
Contact:
Phone:
Email:

Machines will be configured with standard equipment shown unless options are listed below to supersede the standard. Unit price shown in price pages is USD.

| Qty | Machine Type | Model | Price | Base Machine Specification |
|---------------|--|-----------|-----------|----------------------------|
| 1 | Excavator | 9018F CAN | \$ 29,500 | |
| Part Number | Standard Equipment | | | |
| | <ul style="list-style-type: none"> Base unit, with YANMAR 3TNV80 Diesel Tier 4 engine Canopy Open ROPS-TOPS Max digging depth 8 ft 0 in Boom Length 6ft (1685MM) .06 cubic yard G.P. bucket w/ thumb Dual Aux and Piping Hydraulics to front of stick Rubber Tracks 1.58m long (1580mm) & 9" (230mm) Wide 2 way Dozer Blade with blade float Mechanical Suspension Seat Pipes for High pressure Pre-heat and cushion function Proportional Control Joystick with multi botton function ISO-SAE Pattern Changer Articulating boom swing 2" Retractable Seatbelt Retractable Adjustable Undercarriage 2-speed travel system automatic shift w/ travel alarm | | | |
| NOTES: | | | | |

9018F

CAB//CANOPY

EXCAVATOR

| | | | | |
|-----------------------------|--|-----------------------------------|--|---|
| ENGINE Yanmar 3TNV80F | OPERATING WEIGHT 4,189 - 3,969 lb (1,900 - 1,800 kg) | NET POWER 17.1 hp (12.6 kW) | BUCKET CAPACITY 0.06 yd ³ (0.045 m ³) | MAX. DIGGING DEPTH 8 ft 0 in (2.430 mm) |
|-----------------------------|--|-----------------------------------|--|---|



SPECIFICATIONS

ENGINE

| | |
|-------------------|---------------------------------|
| Emissions rating | EPA Tier 4 Final |
| Make | Yanmar |
| Model | 3TNV80F |
| Aspiration | Natural |
| Cooling fan drive | Direct |
| Displacement | 77.5 in ³ (1.3 L) |
| Gross power | 18.2 hp (13.4 kW) @ 2,200 rpm |
| Net power | 17.1 hp (12.6 kW) @ 2,200 rpm |
| Peak torque | 48.2 lb-ft (65.3 N·m) 1,600 rpm |
| Cylinders | 3 |
| Bore x Stroke | 3.1 in x 3.3 in (80 mm x 84 mm) |

HYDRAULIC SYSTEM

| | |
|-----------------------------|-----------------------------------|
| Main Pump | |
| Type | Load-sensing variable piston pump |
| Maximum flow | 15 gal/min (55 L/min) |
| Relief Valve Setting | |
| Implement | 3,046 psi (21 MPa) |
| Travel circuit | 3,046 psi (21 MPa) |
| Slew circuit | 1,914 psi (13.2 MPa) |
| Pilot circuit | 566 psi (3.9 MPa) |

Hydraulic Cylinders

| | |
|-----------------|---------------------------------|
| Boom Cylinder | 2.4 in x 18 in (60 mm x 462 mm) |
| Bore x Stroke | |
| Arm Cylinder | 2.4 in x 14 in (60 mm x 365 mm) |
| Bore x Stroke | |
| Bucket Cylinder | 2.4 in x 11 in (60 mm x 295 mm) |
| Bore x Stroke | |

SERVICE CAPACITIES

| | |
|---------------------|-----------------|
| Fuel tank | 7.4 gal (28 L) |
| Engine oil | 1.2 gal (4.4 L) |
| Cooling system | 0.9 gal (3.3 L) |
| Hydraulic reservoir | 6.3 gal (24 L) |

UNDERCARRIAGE

| | |
|--------------------------|---------------|
| Rubber track assembly | 9 in (230 mm) |
| Bottom rollers each side | 3 |
| Top rollers each side | 0 |

SWING SYSTEM

Planetary gear reduction driven by high torque axial piston motor, with oil disk brake. Swing parking brake resets within five seconds after swing pilot controls return to neutral.

| | |
|--------------|-----------------------|
| Swing speed | 9.5 rpm |
| Swing torque | 1,563 lbf (2,119 N·m) |

DRIVE & BRAKES

2-speed axial piston motors with oil disk brakes. Steering controlled by two detachable hand levers with pedals.

| | |
|-------------------|---|
| Travel speed | High: 2.8 mph (4.5 km/h) Low: 1.7 mph (2.7 km/h) |
| Gradeability | 30° / 58% |
| Max. drawbar pull | 3,597 lb-ft (16 kN) |

ELECTRIC SYSTEM

| | |
|----------------|-----------------------------|
| System voltage | 12V |
| Battery | 12V (one) |
| Alternator | 12V - 40A |
| Starter motor | 12V - 1.9 hp (12V - 1.4 kW) |

SOUND PERFORMANCE

| | |
|---------------------------------|----------|
| Interior sound level (ISO 6396) | 78 dB(A) |
| Exterior sound level (ISO 6395) | 90 dB(A) |

SPECIFICATIONS

EXCLUSIVELY FOR DEALER

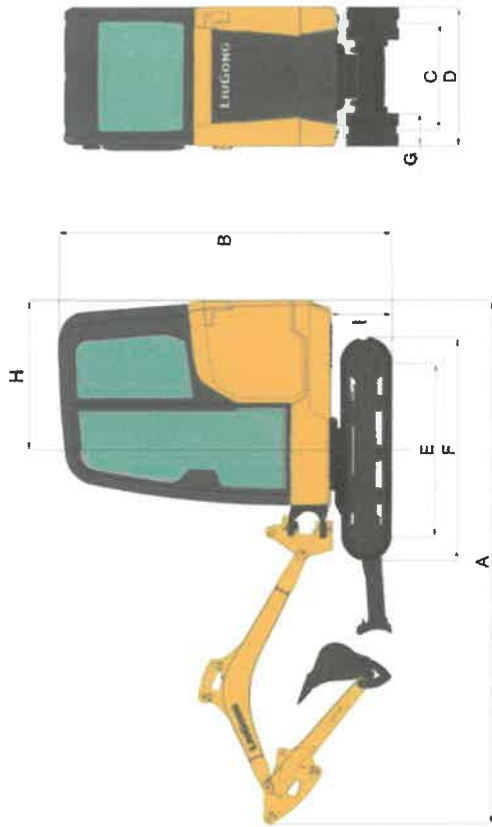
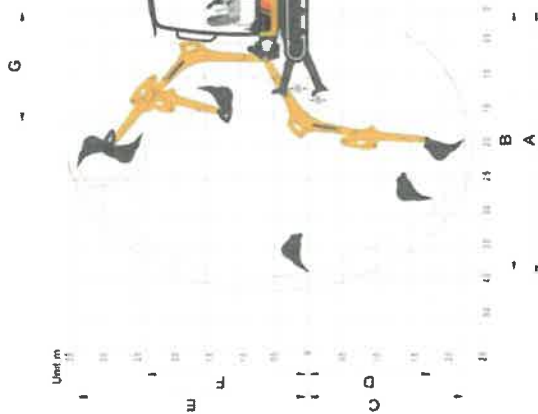

WORKING RANGES

| Description | Standard Cab | Standard Canopy |
|---|-----------------------|--|
| Boom | 4 ft 0 in (1,21 m) | 5 ft 6 in (1,69 m) |
| Arm options | 13 ft 3 in (4,040 mm) | 3 ft 6 in (1,07 m) |
| A Max. digging reach | 13 ft 1 in (3,980 mm) | 12 ft 10 in (3,910 mm) |
| B Max. digging reach at ground level | 8 ft 0 in (2,430 mm) | 12 ft 8 in (3,850 mm) |
| C Max. digging depth | N/A | 7 ft 6 in (2,290 mm) |
| D Max. digging depth 2.4m (8 ft) level bottom | N/A | N/A |
| E Max. digging height | 11 ft 5 in (3,475 mm) | 11 ft 1 in (3,385 mm) |
| F Max. dumping height | 8 ft 1 in (2,460 mm) | 7 ft 9 in (2,370 mm) |
| G Min. front swing radius | 5 ft 7 in (1,700 mm) | 5 ft 5 in (1,660 mm) |
| Dozer up | | 9 in (240 mm) |
| Dozer down | | 9 in (240 mm) |
| Bucket digging force (ISO) | 1,776 lb-ft (8 kN) | 3,697 lbf (16 kN) |
| Arm digging force (ISO) | | 2,023 lb-ft (9 kN) |
| Bucket capacity | | 0.06 yd ³ (0,045 m ³) |
| Bucket tip radius | | 1 ft 10 in (548 mm) |

DIMENSIONS

| Description | Standard Cab | Standard Canopy |
|---|---|-----------------------|
| Boom | 4 ft 0 in (1,21 m) | 5 ft 6 in (1,69 m) |
| Arm options | 12 ft 0 in (3,668 mm) | 10 ft 2 in (3,099 mm) |
| A Shipping length | 2 ft 6 in / 3 ft 6 in (750 mm / 1,060 mm) | 8 ft 0 in (2,438 mm) |
| B Max. shipping height to top of cab/canopy | 3 ft 3 in / 4 ft 3 in (980 mm / 1,295 mm) | 3 ft 3 in (980 mm) |
| C Track gauge (retractable/unretractable) | | 1 ft 5 in (435 mm) |
| D Undercarriage width | | 3 ft 6 in (1,070 mm) |
| E Length to center of rollers | | 1 ft 5 in (435 mm) |
| F Track length | | 5 ft 4 in (1,635 mm) |
| G Track width | | 3 ft 3 in (980 mm) |
| H Tail swing radius | | 3 ft 6 in (1,070 mm) |
| I Counterweight ground clearance | | 5 ft 6 in (1,670 mm) |
| Overall height of cab | | 3 ft 3 in (980 mm) |
| Overall width of the upper-structure | | 1 ft 4 in (419 mm) |
| Max boom offset to the right | | 1 ft 10 in (558 mm) |
| Max boom offset to the left | | 58° |
| Max boom swing angle to the right | | 72° |
| Max boom swing angle to the left | | |

LGNA-SS-9018F-20210103-ENG-US

Specifications and designs are subject to change without notice. Machines shown may include optional equipment.

LiuGong Construction Machinery, N.A., LLC,
22220 Merchants Way - Suite 100
Katy, TX 77449
USA

T: 281-579-6882
www.liugongna.com

F: 281-579-8388



Patrick H. Peters III
Vice President – Regulatory Legal
patrick.peters@centerpointenergy.com

1005 Congress Ave.
Suite 650
Austin, TX 78701
(512) 397-3032

January 26, 2024

Honorable Mayor and City Officials
City of Surfside Beach Village, Texas

Subject: Notice of CenterPoint Energy Houston Electric, LLC Filing to Change Rates

CenterPoint Energy Houston Electric, LLC (“CenterPoint Houston”), in accordance with the Public Utility Regulatory Act, hereby provides notice of its intent to file an application to adjust its rates for both retail and wholesale delivery of electricity not earlier than February 28, 2024, and not later than March 9, 2024.

On the date that CenterPoint Houston files its application at the Public Utility Commission of Texas (“PUCT”), CenterPoint Houston will also provide you with an electronic version of the rate filing application. If you have questions concerning this notice, please contact Ms. Alice Hart at (713) 207-5322.

Sincerely,

A handwritten signature in black ink that reads "P. H. Peters III".

Patrick H. Peters III

*City coalition will review.
Their attys will do the
research. NO COST TO VOSB.*

Ordinance 2024.02.13

AN ORDINANCE AMENDING CHAPTER 46, ARTICLE III, OF THE CODE OF ORDINANCES OF THE VILLAGE OF SURFSIDE BEACH, TEXAS, TO PROVIDE FOR THE REGULATION OF PARKING ON PUBLIC ROADWAYS; REPEALING ALL ORDINANCES OR PARTS OF ORDINANCES IN CONFLICT HEREWITH; PROVIDING A SEVERABILITY CLAUSE; PROVIDING FOR INCLUSION IN THE CODE; CREATING A PENALTY; AND FINDING AND DETERMINING THAT THE MEETING AT WHICH THIS ORDINANCE IS PASSED IS OPEN TO THE PUBLIC AS REQUIRED BY LAW.

WHEREAS, the City Council of the Village of Surfside Beach, Texas, has determined that adoption of this Ordinance is necessary to the health, safety, and general welfare of the inhabitants of said City and the members of the general public; and

WHEREAS, the City Council finds that this Ordinance was adopted at a meeting which was open to the public and preceded by proper notice, as required by Chapter 551 of the Texas Local Government Code (the Open Meetings Act).

NOW, THEREFORE, BE IT ORDAINED BY THE CITY COUNCIL FOR THE VILLAGE OF SURFSIDE BEACH, TEXAS:

FIRST, the findings and recitations set out in the Preamble to this Ordinance are found to be true and correct and they are hereby adopted by the City Council and made part hereof for all purposes.

SECOND, That Chapter 46, Article III, of the Code of Ordinances of the Village of Surfside Beach, Texas, is hereby adopted to read as follows:

Sec. 46-128. – Same – Bluewater Highway (County Road 257).

- (a) No person shall park a vehicle on either the north side or the south side of Bluewater Highway (County Rd 257) from Highway 332 all the way North to the city limits of the Village of Surfside Beach.
- (b) Any vehicle parked there is subject to being towed and stored at the owner's expense, in addition to a citation.

THIRD, This Ordinance shall be and is hereby declared to be cumulative of all other Ordinances of the Village of Surfside Beach and this Ordinance shall not operate to repeal or affect any of such other Ordinances except insofar as the provisions thereof might be inconsistent or in

conflict with the provisions of this Ordinance, in which event such conflicting provisions, if any, in such other Ordinance or Ordinances are hereby repealed.

FOURTH, If any section, subsection, sentence, clause, or phrase, of this Ordinance is for any reason held to be unconstitutional, such holding shall not affect the validity of the remaining portions of this Ordinance.

FIFTH, All of the regulations provided in this Ordinance are hereby declared to be governmental and for the health, safety, and welfare of the general public. Any member of the City Council or any City official or employee charged with the enforcement of this Ordinance, acting for the Village of Surfside Beach in the discharge of his/her duties, shall not thereby render himself/herself personally liable; and he/she is hereby relieved from all personal liability for any damage that might accrue to persons or property as a result of any act required or permitted in the discharge of his/her said duties.

SIXTH, Any violation of this Ordinance can be enjoined by a suit filed in the name of the Village of Surfside Beach in a court of competent jurisdiction, and this remedy shall be in addition to any penal provision in this Ordinance or in the Code of the Village of Surfside Beach.

SEVENTH, This Ordinance shall take effect and be in force immediately upon its passage and publication of its descriptive caption twice in the Brazosport Facts.

READ, PASSED, AND ADOPTED THIS 13th DAY OF February, 2024.

GREGG BISSO, MAYOR
VILLAGE OF SURFSIDE BEACH, TEXAS

ATTEST: _____
AMANDA DAVENPORT
CITY SECRETARY

Amanda Davenport

From: Jon Gerber
Sent: Thursday, March 7, 2024 11:22 AM
To: Amanda Davenport
Subject: Agenda

Discuss and take possible action regarding : Approval of location near the Timeline Fence for DRT (Daughters of the Republic of Texas)(and future) insignia medallions from other historically related groups , and proposed landscaping around monument.

Thank You

Jonathan Gerber
Alderman At Large.

Sent from my iPhone

Amanda Davenport

From: Jon Gerber
Sent: Thursday, March 7, 2024 8:50 AM
To: Amanda Davenport
Subject: Agenda

Discuss and take possible action to establish the Chief's Advisory Panel for the Surfside Beach Texas Police Department.

The primary purpose of the Chief's Advisory Panel (CAP) is to serve as a resource in the formation of strategies, development of community policing concepts, solicitation of community feedback, and enhancement of community trust.

The CAP is not a forum for the review of specific police actions. Rather, the CAP allows the Chief to regularly engage with a diverse group of citizens and Surfside Beach Police Department representatives about department initiatives and needs as well as community concerns, leveraging the experience of persons both inside and outside of policing to integrate community viewpoints into department planning and strategies.

Meetings: The CAP meets at least six times each year. When formal presentations are made, the public is invited to attend that portion of the meeting.

Membership: The CAP is composed of five citizens each to be nominated by an Alderman of the Surfside Village Council and confirmed by a majority vote of the Surfside Village Council, representing the diversity of the Village as well as three employees representing sworn and professional staff from within the police department. Members serve two-year terms with no more than two consecutive terms.

Policy: CAP will work with the Surfside Beach Police Department as one part of an overall strategy of outreach into our community to fulfill the goal of building trust and relationships with residents and business owners. The CAP is to provide a regular forum for citizen and department representatives to engage in candid and respectful discussions regarding public safety issues to further enhance quality of life and safety in our community.

PURPOSE: The primary purpose of the CAP is to serve as a resource in the formation of strategies, development of community policing concepts, solicitation of community feedback, and enhancement of community trust. The CAP is not a forum for the review of specific police actions, whether internal or external. Rather, the CAP allows the Chief and Police Department to regularly engage with a diverse group of citizens and department representatives about department initiatives and needs as well as community concerns, leveraging the experience of persons both inside and outside of policing to integrate

community viewpoints into department planning and strategies. Specifically, the purposes of the CAP are to:

- A. build and maintain a respectful relationship with the Chief and department employees;
- B. provide informed, honest input on law enforcement-related issues facing the community;
- C. advise the Chief on the development of strategies to address specific policy issues;
- D. convey issues and concerns when gaps in service or alleged misconduct are identified;
- E. serve as a conduit for receiving information from and providing information to the community and department employees.

CITIZEN MEMBERS

The panel shall include five (5) citizens.

A. Membership Criteria. Citizen members shall:

- 1. be a Surfside Texas resident, property or business owner for at least the last six consecutive months.
- 2. not have been convicted of a felony
- 3. be nominated by an Alderman and confirmed by Surfside Village Council

Thank You,

Jonathan Gerber

Alderman At Large

Surfside Texas

Sent from my iPhone

Amanda Davenport

From: Jon Gerber
Sent: Thursday, March 7, 2024 9:36 AM
To: Amanda Davenport
Subject: Agenda

Good morning,

I am concerned with Council and staff's ability to fully and legally discuss and be updated as to the performance of all Municipal Court Judges that serve in our municipality in the upcoming closed session, concerned that we may touch on issues that have not been fully disclosed in accordance with the Open Meetings Act through the posted agenda item from our cancelled February meeting.

Although I appreciate the help you gave with revisions...,

I believe the wording of my original agenda request may more accurately reflect the conversation that may occur.

If there is not enough specificity let me know, I would like to discuss and take action regarding current , former, as well as the appointment of new Municipal Court Judges.

Thank You

Jonathan Gerber
Alderman At Large



Jon Gerber

To: Amanda Davenport >

2/3

Agenda February 2024

Agenda Item:

I hereby request for the Surfside City Council adjourn into an EXECUTIVE SESSION (closed executive session pursuant section 551.074 of the Texas Government Code) to discuss personnel matters - specifically, matters involving the appointment/re-appointment, employment, evaluation, reassignment, resignation and duties of the Judges serving the Surfside Municipal Court.

Thank You

Jonathan Gerber

Alderman At Large